

YZR YZ 系列冶金及起重用三相异步电动机

YZR、YZ Series Induction Motors For Cranes And Metallurgical Applications



机座号 YZ112~250
YZR112~400

功率 1.5~30kW
1.5~200kW

基准工作制 S3

负载持续率 (FC) 40%

一般环境用 (40°C)
冶金环境用 (60°C)

F 级绝缘 IP44
H 级绝缘 IP54

适用于: 冶金和矿山行业中驱动各种型式的起重机械及其它类似设备, 特别适用于短时或断续周期性运转, 频繁启动、制动, 有时过负载及有显著振动与冲击的设备。

Applications: All metallurgy and lifting machines or the similar equipment. It is suitable for driving the short time on duty or continuous on duty equipment that frequent starting, braking and significant vibration and impacting is existed. Basic Duty Type is S3 at 40% Load Duration.

特点: 具有较大的过载能力和较高的机械强度, YZR 系列为绕线转子电动机, YZ 系列为鼠笼转子电动机。

Features: Processes the ability of overload and mechanic strength. The type of YZR series rotor is winding rotor, but YZ series is squirrel-cage rotor.

性能数据 Performance Data

YZ

| 型号 | 工作制 | S3 | | | | | | | | | | | | | | | | | | 转动惯量 (kg.m ²) | | | | | |
|----------------|-----|---------------------|---------|-----|------------------|---------|-----|------------------|---------|-----|------------------|---------|-----|------------------|---------|----------------|-----------------|-------------------|-----|---------------------------|---------|-----|------------------|---------|-------|
| | | 6 次/小时 6starts/hour | | | | | | | | | | | | | | | | | | | | | | | |
| | | 30 分钟 | | | 60 分钟 | | | 15% | | | 25% | | | 40% | | | 60% | | | | 100% | | | | |
| 项目 | kW | I ₁ A | n r/min | kW | I ₁ A | n r/min | kW | I ₁ A | n r/min | kW | I ₁ A | n r/min | kW | I ₁ A | n r/min | T _m | T _{st} | I _{st} A | kW | I ₁ A | n r/min | kW | I ₁ A | n r/min | |
| 同步转速 1000r/min | | | | | | | | | | | | | | | | | | | | | | | | | |
| YZ112M | 1.8 | 4.9 | 892 | 1.5 | 4.3 | 920 | 2.2 | 6.5 | 810 | 1.8 | 4.9 | 892 | 1.5 | 4.3 | 920 | 2 | 2 | 20 | 1.1 | 2.7 | 946 | 0.8 | 3.5 | 980 | 0.022 |
| YZ132M1 | 2.5 | 6.5 | 920 | 2.2 | 5.9 | 935 | 3 | 7.5 | 804 | 2.5 | 6.5 | 920 | 2.2 | 5.9 | 935 | 2 | 2 | 27 | 1.8 | 5.3 | 950 | 1.5 | 4.9 | 960 | 0.056 |
| YZ132M2 | 4 | 9.2 | 915 | 3.7 | 8.8 | 912 | 5 | 12 | 890 | 4 | 9.2 | 915 | 3.7 | 8.8 | 912 | 2 | 2 | 42 | 3 | 7.5 | 940 | 2.5 | 7.2 | 945 | 0.062 |
| YZ160M1 | 6.3 | 14 | 922 | 5.5 | 13 | 933 | 7.5 | 17 | 903 | 6.3 | 14 | 922 | 5.5 | 13 | 933 | 2 | 2 | 60 | 5 | 12 | 940 | 4 | 10 | 953 | 0.114 |
| YZ160M2 | 8.5 | 18 | 943 | 7.5 | 16 | 948 | 11 | 25 | 926 | 8.5 | 18 | 943 | 7.5 | 16 | 948 | 2.3 | 2.3 | 92 | 6.3 | 14 | 956 | 5.5 | 13 | 961 | 0.143 |
| YZ160L | 13 | 29 | 936 | 11 | 25 | 953 | 15 | 32 | 920 | 13 | 29 | 936 | 11 | 25 | 953 | 2.5 | 2.5 | 140 | 9 | 21 | 964 | 7.5 | 19 | 972 | 0.192 |
| 同步转速 750r/min | | | | | | | | | | | | | | | | | | | | | | | | | |
| YZ160L | 9 | 21 | 694 | 7.5 | 18 | 705 | 11 | 27 | 675 | 9 | 21 | 694 | 7.5 | 18 | 705 | 2.3 | 2.3 | 98 | 6 | 16 | 717 | 5 | 14 | 724 | 0.192 |
| YZ180L | 13 | 30 | 675 | 11 | 26 | 694 | 15 | 35 | 654 | 13 | 30 | 675 | 11 | 26 | 694 | 2.5 | 2.5 | 130 | 9 | 22 | 710 | 7.5 | 19 | 718 | 0.352 |
| YZ200L | 19 | 40 | 697 | 15 | 33 | 710 | 22 | 48 | 686 | 19 | 40 | 697 | 15 | 33 | 710 | 2.5 | 2.5 | 182 | 13 | 28 | 714 | 11 | 26 | 720 | 0.622 |
| YZ225M | 26 | 54 | 701 | 22 | 46 | 712 | 33 | 69 | 687 | 26 | 54 | 701 | 22 | 46 | 712 | 2.5 | 2.5 | 275 | 19 | 40 | 718 | 17 | 38 | 720 | 0.82 |
| YZ250M1 | 35 | 74 | 681 | 30 | 63 | 694 | 42 | 89 | 663 | 35 | 74 | 681 | 30 | 63 | 694 | 2.5 | 2.5 | 350 | 26 | 56 | 702 | 22 | 45 | 717 | 1.432 |



性能数据 Performance Data

YZR

| 型号 | 工作制 FC | S2 | | | | | | | | | | | | | | | | S3 | | | | | | | | | | | | | | | | | | | | | | | |
|-----------------|-----------|----------|------|-----|-----|----------|-------|-----|-----|------|------|-----|------|------|------|-----|-----|------------------|------|-----|------|-----|------|------|------|------|------|-----|-----|------|------|-----|----|---|--|--|--|--|--|--|--|
| | | | | | | | | | | | | | | | | | | 6次/小时 6 starts/h | | | | | | | | | | | | | | | | | | | | | | | |
| | | 30分钟 min | | | | 60分钟 min | | | | 15% | | | | 25% | | | | 40% | | | | | | | | 60% | | | | 100% | | | | | | | | | | | |
| | | 项目 | kW | I1 | I2 | n | kW | I1 | I2 | n | kW | I1 | I2 | n | kW | I1 | I2 | n | kW | I1 | I2 | Tm | I0 | n | η | cosφ | kW | I1 | I2 | n | kW | I1 | I2 | n | | | | | | | |
| 同步转速 1000 r/min | | | | | | | | | | | | | | | | | | | | | | | | | | | | | | | | | | | | | | | | | |
| YZR112M | 1.8 | 5.3 | 13.4 | 815 | 1.5 | 4.6 | 12.5 | 866 | 2.2 | 6.6 | 18.4 | 725 | 1.8 | 5.3 | 13.4 | 815 | 1.5 | 4.6 | 12.5 | 2.3 | 3.37 | 866 | 65 | 0.77 | 1.1 | 3.8 | 7.32 | 912 | 0.8 | 3.5 | 5.16 | 940 | | | | | | | | | |
| YZR132M1 | 2.5 | 6.5 | 12.9 | 892 | 2.2 | 6.1 | 12.6 | 908 | 3 | 8 | 16.1 | 855 | 2.5 | 6.5 | 12.9 | 892 | 2.2 | 6 | 12.6 | 2.3 | 4.04 | 908 | 70 | 0.77 | 1.8 | 5.4 | 8.96 | 921 | 1.5 | 5 | 7.3 | 940 | | | | | | | | | |
| YZR132M2 | 4 | 9.7 | 14.2 | 900 | 3.7 | 9.2 | 14.5 | 908 | 5 | 12.3 | 18.2 | 875 | 4 | 9.7 | 14.2 | 900 | 3.7 | 9.2 | 14.5 | 2.3 | 8.58 | 908 | 75.5 | 0.78 | 3 | 7.9 | 10.2 | 937 | 2.5 | 7.5 | 8.4 | 950 | | | | | | | | | |
| YZR160M1 | 6.3 | 16.4 | 29.4 | 921 | 5.5 | 15 | 25.7 | 930 | 7.5 | 18.5 | 35.4 | 910 | 6.3 | 16.4 | 29.4 | 921 | 5.5 | 15 | 25.7 | 2.3 | 7.95 | 930 | 75.5 | 0.78 | 5 | 14 | 22.9 | 935 | 4 | 12.5 | 18.2 | 944 | | | | | | | | | |
| YZR160M2 | 8.5 | 19.6 | 29.8 | 930 | 7.5 | 18 | 26.5 | 940 | 11 | 24.6 | 39.6 | 908 | 8.5 | 19.6 | 29.8 | 930 | 7.5 | 18 | 26.5 | 2.5 | 11.2 | 940 | 79 | 0.8 | 6.3 | 16 | 21.7 | 949 | 5.5 | 15 | 18.8 | 956 | | | | | | | | | |
| YZR160L | 13 | 28.6 | 31.6 | 942 | 11 | 24.5 | 27.6 | 957 | 15 | 34.7 | 39 | 920 | 13 | 28.6 | 31.6 | 912 | 11 | 25 | 27.6 | 2.5 | 13 | 945 | 82 | 0.8 | 9 | 21 | 22.3 | 952 | 7.5 | 18.8 | 18.5 | 970 | | | | | | | | | |
| YZR180L | 17 | 36.7 | 49.8 | 955 | 15 | 33.8 | 46.5 | 962 | 20 | 42.6 | 58.7 | 946 | 17 | 36.7 | 49.8 | 955 | 15 | 33.8 | 46.5 | 2.8 | 18.8 | 962 | 84 | 0.81 | 13 | 29.7 | 37.3 | 968 | 11 | 25.5 | 31.5 | 975 | | | | | | | | | |
| YZR200L | 26 | 56.1 | 82.4 | 956 | 22 | 49 | 69.9 | 964 | 33 | 62 | 103 | 942 | 26 | 56 | 82.4 | 956 | 22 | 49 | 70 | 2.8 | 26.6 | 964 | 86 | 0.8 | 19 | 44.5 | 60.5 | 969 | 17 | 40.5 | 52.6 | 973 | | | | | | | | | |
| YZR225M | 34 | 70 | 85 | 957 | 30 | 62 | 74.4 | 962 | 40 | 80 | 101 | 917 | 34 | 70 | 85 | 957 | 30 | 62 | 74.4 | 2.8 | 29.9 | 962 | 88 | 0.82 | 26 | 55 | 64.5 | 968 | 22 | 50 | 54.2 | 975 | | | | | | | | | |
| YZR250M1 | 42 | 80 | 103 | 960 | 37 | 70.5 | 91.5 | 965 | 50 | 99 | 123 | 950 | 42 | 80 | 103 | 960 | 37 | 70.5 | 91.5 | 2.8 | 26.5 | 960 | 89 | 0.89 | 32 | 61 | 79 | 970 | 28 | 55 | 69 | 975 | | | | | | | | | |
| YZR250M2 | 52 | 97 | 110 | 958 | 45 | 84.5 | 95 | 965 | 63 | 121 | 134 | 947 | 52 | 97 | 110 | 958 | 45 | 84.5 | 95 | 2.8 | 28.2 | 965 | 90.5 | 0.89 | 39 | 73 | 83 | 969 | 33 | 64 | 71 | 974 | | | | | | | | | |
| YZR280S | 63 | 118 | 142 | 966 | 55 | 102 | 129.8 | 969 | 75 | 144 | 170 | 960 | 63 | 118 | 142 | 966 | 55 | 102 | 120 | 2.8 | 34 | 969 | 91 | 0.9 | 48 | 88 | 107 | 972 | 40 | 76 | 89 | 976 | | | | | | | | | |
| YZR280M | 85 | 157 | 140 | 966 | 75 | 139 | 124 | 970 | 100 | 185 | 166 | 960 | 85 | 157 | 140 | 966 | 75 | 139 | 124 | 2.8 | 47.5 | 970 | 91.8 | 0.89 | 63 | 118 | 104 | 975 | 50 | 96.3 | 82 | 980 | | | | | | | | | |
| 同步转速 750r/min | | | | | | | | | | | | | | | | | | | | | | | | | | | | | | | | | | | | | | | | | |
| YZR160L | 9 | 22.4 | 28.1 | 694 | 7.5 | 19.1 | 23 | 705 | 11 | 27.5 | 35.5 | 676 | 9 | 22.4 | 28.1 | 694 | 7.5 | 19.1 | 23 | 2.5 | 12.7 | 705 | 78.5 | 0.72 | 6 | 16.4 | 18.2 | 712 | 5 | 14 | 15 | 724 | | | | | | | | | |
| YZR180L | 13 | 29.1 | 47.8 | 700 | 11 | 27 | 44 | 700 | 15 | 34 | 56 | 690 | 13 | 29.1 | 47.8 | 700 | 11 | 27 | 44 | 2.5 | 14.8 | 700 | 81 | 0.77 | 9 | 21.9 | 32.1 | 720 | 7.5 | 19.6 | 26.6 | 726 | | | | | | | | | |
| YZR200L | 18.5 | 40 | 67.2 | 701 | 15 | 33.5 | 53.5 | 712 | 22 | 48 | 81 | 690 | 18.5 | 40 | 67.2 | 701 | 15 | 33.5 | 53.5 | 2.8 | 17.8 | 712 | 85 | 0.78 | 13 | 30 | 46 | 718 | 11 | 27 | 38.7 | 723 | | | | | | | | | |
| YZR225M | 26 | 55 | 71.2 | 708 | 22 | 46.9 | 59.1 | 715 | 33 | 70 | 92 | 696 | 26 | 55 | 71.2 | 708 | 22 | 46.9 | 59.1 | 2.8 | 24.2 | 715 | 86 | 0.79 | 18.5 | 41 | 49.5 | 721 | 17 | 38 | 45 | 723 | | | | | | | | | |
| YZR250M1 | 35 | 64 | 80 | 715 | 30 | 63.4 | 67.7 | 720 | 42 | 75 | 97.5 | 710 | 35 | 64 | 80 | 715 | 30 | 63.4 | 68.8 | 2.8 | 31.4 | 720 | 87 | 0.8 | 26 | 52 | 59 | 725 | 22 | 46 | 49.7 | 729 | | | | | | | | | |
| YZR250M2 | 42 | 86 | 79 | 716 | 37 | 78 | 70 | 720 | 52 | 103 | 98 | 706 | 42 | 86 | 79 | 716 | 37 | 78 | 70 | 2.8 | 36.9 | 720 | 88 | 0.82 | 32 | 68 | 60 | 725 | 27 | 60 | 51 | 729 | | | | | | | | | |
| YZR280S | 52 | 108 | 106 | 712 | 45 | 96.5 | 92 | 717 | 63 | 129 | 130 | 704 | 52 | 108 | 106 | 712 | 45 | 96.5 | 92 | 2.8 | 48 | 717 | 88.8 | 0.8 | 39 | 86 | 79.4 | 722 | 33 | 76.3 | 67 | 726 | | | | | | | | | |
| YZR280M | 63 | 126 | 110 | 722 | 55 | 111 | 92.5 | 725 | 75 | 150 | 132 | 715 | 63 | 126 | 110 | 722 | 55 | 111 | 92.5 | 2.8 | 52.3 | 725 | 89 | 0.84 | 48 | 103 | 82.8 | 730 | 40 | 93 | 68.7 | 732 | | | | | | | | | |
| YZR315S | 85 | 165 | 178 | 722 | 75 | 147 | 157 | 725 | 100 | 200 | 162 | 715 | 85 | 165 | 178 | 722 | 75 | 146 | 157 | 2.8 | 62 | 725 | 89 | 0.85 | 63 | 126 | 131 | 729 | 55 | 105 | 104 | 731 | | | | | | | | | |
| YZR315M | 100 | 190 | 184 | 715 | 90 | 172 | 161 | 720 | 125 | 250 | 232 | 717 | 100 | 190 | 184 | 715 | 90 | 172 | 161 | 2.8 | 57.7 | 720 | 90 | 0.87 | 75 | 140 | 136 | 725 | 63 | 124 | 114 | 728 | | | | | | | | | |
| 同步转速 600r/min | | | | | | | | | | | | | | | | | | | | | | | | | | | | | | | | | | | | | | | | | |
| YZR280S | 42 | 92 | 177 | 571 | 37 | 84.8 | 153 | 560 | 55 | 112 | 235 | 564 | 42 | 92 | 177 | 571 | 37 | 84.8 | 153 | 2.8 | 44.2 | 572 | 86 | 0.76 | 32 | 77 | 133 | 578 | 27 | 69 | 112 | 582 | | | | | | | | | |
| YZR280M | 55 | 127 | 207 | 556 | 45 | 104 | 165 | 560 | 63 | 146 | 241 | 548 | 55 | 127 | 207 | 556 | 45 | 104 | 165 | 2.8 | 63.6 | 560 | 86 | 0.77 | 37 | 90 | 136 | 569 | 33 | 89.6 | 118 | 587 | | | | | | | | | |
| YZR315S | 63 | 132 | 162 | 580 | 55 | 118 | 139 | 580 | 75 | 154 | 194 | 574 | 63 | 133 | 162 | 580 | 55 | 118 | 139 | 2.8 | 62.5 | 580 | 88.5 | 0.79 | 48 | 107 | 122 | 585 | 40 | 95.2 | 101 | 588 | | | | | | | | | |
| YZR315M | 85 | 179 | 171 | 576 | 75 | 160 | 149 | 579 | 100 | 210 | 203 | 570 | 85 | 179 | 171 | 576 | 75 | 160 | 149 | 2.8 | 85.3 | 579 | 89 | 0.79 | 63 | 140 | 125 | 584 | 50 | 125 | 98.5 | 587 | | | | | | | | | |
| YZR355M | 110 | 218 | 207 | 581 | 90 | 180 | 167 | 585 | 132 | 266 | 252 | 576 | 110 | 218 | 207 | 581 | 90 | 180 | 167 | 2.8 | 83 | 589 | 90 | 0.81 | 75 | 154 | 140 | 588 | 63 | 136 | 117 | 589 | | | | | | | | | |
| YZR355L1 | 132 | 257 | 213 | 576 | 110 | 217 | 172 | 582 | 160 | 314 | 261 | 571 | 132 | 257 | 213 | 587 | 110 | 217 | 172 | 2.8 | 90 | 582 | 91 | 0.82 | 90 | 181 | 143 | 585 | 75 | 157 | 119 | 588 | | | | | | | | | |
| YZR355L2 | 150 | 293 | 194 | 588 | 132 | 262 | 168 | 588 | 185 | 353 | 241 | 585 | 150 | 293 | 194 | 588 | 132 | 262 | 168 | 2.8 | 126 | 588 | 92 | 0.82 | 110 | 226 | 142 | 591 | 90 | 191 | 116 | 592 | | | | | | | | | |
| YZR400L1 | 190 | 390 | 290 | 585 | 160 | 338 | 244 | 587 | 220 | 445 | 336 | 581 | 190 | 390 | 290 | 584 | 160 | 338 | 244 | 2.8 | 175 | 587 | 91.5 | 0.79 | 135 | 294 | 206 | 592 | 115 | 268 | 174 | 591 | | | | | | | | | |
| YZR400L2 | 240 | 490 | 302 | 585 | 200 | 427 | 252 | 588 | 270 | 540 | 340 | 582 | 240 | 490 | 302 | 586 | 200 | 423 | 252 | 2.8 | 213 | 588 | 92.2 | 0.77 | 170 | 372 | 214 | 591 | 145 | 332 | 183 | 592 | | | | | | | | | |



性能数据 Performance Data

YZR

| 型号 | 工作制 | S4、S5 | | | | | | | | | | | | | | | | | | | | | | | |
|----------------|-----|-----------------------|-------|-----|------|-------|-------|-----|-----|------|-------|-----|-----|-----------------------|-------|-----|-----|------|-------|----------------------|------|------|-------|-----|----|
| | | 150 次/小时 150 starts/h | | | | | | | | | | | | 300 次/小时 300 starts/h | | | | | | 600 次/小时 600starts/h | | | | | |
| | FC | 25% | | | | 40% | | | | 60% | | | | 40% | | | | 60% | | | | 60% | | | |
| | | 项目 | kW | I1 | I2 | n | kW | I1 | I2 | n | kW | I1 | I2 | n | kW | I1 | I2 | n | kW | I1 | I2 | n | kW | I1 | I2 |
| 同步转速 1000r/min | | | | | | | | | | | | | | | | | | | | | | | | | |
| YZR112M | 1.6 | 4.75 | 11.3 | 845 | 1.3 | 4.2 | 8.85 | 890 | 1 | 3.75 | 6.57 | 920 | 1.2 | 4 | 8 | 900 | 0.9 | 3.7 | 5.87 | 930 | 0.7 | 3.4 | 4.46 | 946 | |
| YZR132M | 2.2 | 6 | 11.2 | 908 | 2 | 5.7 | 10 | 913 | 1.7 | 5.3 | 8.4 | 931 | 1.8 | 5.4 | 9 | 926 | 1.6 | 5.1 | 7.87 | 936 | 1.35 | 4.9 | 6.8 | 946 | |
| YZR132M | 3.7 | 9.7 | 13.1 | 915 | 3.5 | 9.2 | 11.2 | 925 | 2.8 | 8.5 | 9.65 | 940 | 3.3 | 9.4 | 11.9 | 925 | 2.7 | 8.5 | 9.65 | 940 | 2.3 | 6 | 7.5 | 950 | |
| YZR160M | 5.8 | 15.5 | 27.3 | 927 | 5 | 14.1 | 23.4 | 935 | 4.8 | 13.5 | 22.7 | 937 | 4.8 | 14.1 | 23.4 | 935 | 4.5 | 13.8 | 22.4 | 937 | 3.8 | 12.2 | 17.5 | 946 | |
| YZR160M | 7.5 | 18 | 27.6 | 940 | 7 | 17.1 | 25.6 | 945 | 6 | 15.6 | 21.8 | 954 | 6 | 15.6 | 21.8 | 954 | 5.5 | 14.8 | 19.8 | 959 | 4 | 13 | 14.2 | 970 | |
| YZR160L | 11 | 28.3 | 27.8 | 950 | 10 | 23 | 25 | 957 | 8 | 19.5 | 19.8 | 969 | 9 | 19.5 | 19.8 | 969 | 7.5 | 18.7 | 18.5 | 971 | 6 | 16.7 | 14.2 | 978 | |
| YZR180L | 15 | 33 | 43.7 | 960 | 13 | 29.5 | 37.7 | 965 | 12 | 28 | 34.6 | 969 | 12 | 28 | 34.6 | 969 | 11 | 26.6 | 31.7 | 972 | 9 | 23.6 | 22.9 | 978 | |
| YZR200L | 21 | 47 | 55.4 | 965 | 18.5 | 42.5 | 48.5 | 970 | 17 | 40.5 | 53.8 | 973 | 17 | 40.5 | 52.6 | 973 | 15 | 37 | 40 | 975 | 11 | 31.5 | 28.5 | 981 | |
| YZR225M | 28 | 58 | 70 | 965 | 25 | 53 | 62.2 | 969 | 22 | 50 | 54.5 | 973 | 22 | 50 | 54.5 | 973 | 20 | 46 | 49.4 | 977 | 15 | 39 | 36.8 | 982 | |
| YZR250M | 33 | 63 | 82.6 | 970 | 30 | 58 | 74.9 | 973 | 28 | 54 | 69.8 | 975 | 26 | 52 | 64.6 | 977 | 25 | 50 | 62.1 | 978 | 17.5 | 39 | 43.2 | 984 | |
| YZR250M | 42 | 78 | 90.5 | 967 | 37 | 70 | 79.3 | 971 | 33 | 63 | 70.5 | 975 | 31 | 60 | 66.1 | 976 | 30 | 58 | 63.9 | 977 | 24 | 49 | 50.9 | 981 | |
| YZR280S | 52 | 95 | 116 | 970 | 45 | 83 | 100 | 974 | 42 | 80 | 93.6 | 975 | 40 | 76 | 89 | 977 | 37 | 71 | 82.2 | 978 | 30 | 64 | 66.5 | 980 | |
| YZR280M | 70 | 130 | 115 | 972 | 62 | 114 | 102 | 975 | 55 | 91 | 104 | 978 | 52 | 98 | 85.5 | 979 | 47 | 92 | 77.3 | 981 | 37 | 78 | 61 | 982 | |
| 同步转速 750r/min | | | | | | | | | | | | | | | | | | | | | | | | | |
| YZR160L | 7.5 | 19 | 22.8 | 712 | 7 | 18.1 | 21.2 | 716 | 5.8 | 16.4 | 17.3 | 724 | 6 | 16.7 | 18 | 722 | 5 | 15.5 | 14.9 | 727 | 3.8 | 13.7 | 11.2 | 732 | |
| YZR180L | 11 | 25.4 | 40.6 | 711 | 10 | 23.5 | 36.6 | 717 | 8 | 20.5 | 28.8 | 728 | 8 | 20.5 | 28.8 | 728 | 7.5 | 19.7 | 26.9 | 729 | 5.8 | 17.8 | 20.6 | 736 | |
| YZR200L | 15 | 34 | 54.1 | 713 | 13 | 30 | 46.6 | 718 | 12 | 28.2 | 43 | 720 | 12 | 28.2 | 43 | 720 | 11 | 27 | 39 | 724 | 9 | 23 | 28.1 | 731 | |
| YZR225M | 21 | 45 | 56.8 | 718 | 18.5 | 41 | 49.7 | 721 | 17 | 38 | 45.6 | 724 | 17 | 38 | 45.6 | 724 | 15 | 35 | 40 | 727 | 11 | 31 | 29.1 | 733 | |
| ZR250M1 | 29 | 61.5 | 68.5 | 700 | 25 | 54 | 58.7 | 705 | 22 | 49 | 51.9 | 712 | 22 | 49 | 51.9 | 712 | 20 | 46 | 46.2 | 716 | 15 | 39 | 34.2 | 725 | |
| YZR250M | 33 | 70 | 62.5 | 725 | 30 | 64 | 56.6 | 727 | 28 | 61 | 52.8 | 728 | 26 | 58 | 48.9 | 730 | 25 | 57 | 47 | 731 | 18.5 | 45 | 34.4 | 736 | |
| YZR280S | 42 | 91 | 85.8 | 719 | 37 | 83 | 75.6 | 723 | 33 | 76.3 | 67 | 726 | 31 | 74 | 63.5 | 728 | 30 | 72 | 61.5 | 732 | 24 | 64 | 49 | 733 | |
| YZR280M | 52 | 104 | 90.2 | 727 | 45 | 93 | 77.7 | 730 | 42 | 89 | 72.4 | 732 | 42 | 89 | 72.4 | 732 | 37 | 83 | 63.5 | 735 | 30 | 73 | 51.4 | 737 | |
| YZR315S | 64 | 118 | 132.7 | 731 | 60 | 110.5 | 124.2 | 733 | 56 | 106 | 115.8 | 733 | 52 | 100 | 107 | 735 | 48 | 94 | 98.8 | 736 | 35 | 80 | 71.7 | 740 | |
| YZR315M | 75 | 142 | 136 | 725 | 72 | 136 | 130.7 | 725 | 65 | 126 | 117.6 | 727 | 60 | 120 | 108 | 729 | 55 | 116 | 99 | 729 | 41 | 100 | 73.7 | 732 | |
| 同步转速 600 r/min | | | | | | | | | | | | | | | | | | | | | | | | | |
| YZR280S | 33 | 78.7 | 141.8 | 578 | 30 | 74 | 125 | 579 | 28 | 71 | 116 | 580 | 26 | 68 | 108 | 582 | 25 | 66 | 103 | 583 | 17 | 56 | 69.8 | 588 | |
| YZR280M | 42 | 98.7 | 154 | 565 | 37 | 90 | 136 | 569 | 33 | 84.3 | 118 | 573 | 31 | 82 | 110 | 574 | 28 | 78.5 | 98 | 577 | 22 | 72.5 | 75 | 582 | |
| YZR315S | 50 | 110 | 128.4 | 583 | 45 | 100 | 115.3 | 585 | 42 | 96 | 107.4 | 586 | 40 | 94 | 102.2 | 587 | 37 | 90 | 94.5 | 587 | 30 | 84 | 76.3 | 589 | |
| YZR315M | 65 | 144 | 129 | 584 | 63 | 136 | 119 | 585 | 55 | 130 | 109 | 586 | 53 | 126 | 98.7 | 587 | 48 | 124 | 94.7 | 588 | 37 | 114 | 73 | 589 | |
| YZR355M | 80 | 160.5 | 149.7 | 587 | 72 | 156 | 134.5 | 588 | 65 | 140 | 121 | 589 | 60 | 130 | 112 | 590 | 55 | 124 | 102.4 | 590 | 41 | 104 | 76.19 | 591 | |
| YZR355L1 | 100 | 185 | 157 | 586 | 90 | 170 | 142 | 588 | 80 | 155 | 126.5 | 589 | 75 | 150 | 119 | 590 | 70 | 145 | 111 | 591 | 50 | 120 | 78.4 | 594 | |
| YZR355L2 | 120 | 250 | 149.8 | 588 | 110 | 230 | 137.5 | 589 | 95 | 210 | 122.7 | 591 | 90 | 205 | 116.2 | 591 | 80 | 190 | 130.2 | 592 | 60 | 165 | 77.1 | 594 | |
| YZR400L1 | 146 | 314 | 223 | 588 | 130 | 288 | 199 | 589 | 115 | 268 | 175 | 590 | 110 | 260 | 168 | 591 | 97 | 247 | 148 | 592 | 75 | 220 | 114 | 594 | |
| YZR400L2 | 185 | 396 | 223 | 590 | 165 | 365 | 262 | 589 | 145 | 332 | 183 | 592 | 140 | 324 | 176 | 592 | 123 | 298 | 155 | 592 | 95 | 265 | 122 | 594 | |

外形及安装尺寸 Dimensions

mm

IM1001、IM1002 及 IM1003、IM1004 机座带底脚、端盖上无凸缘的 YZ 系列电机
 Frame with feet and endshield without flange (IM1001,IM1002,IM1003,IM1004)

YZ

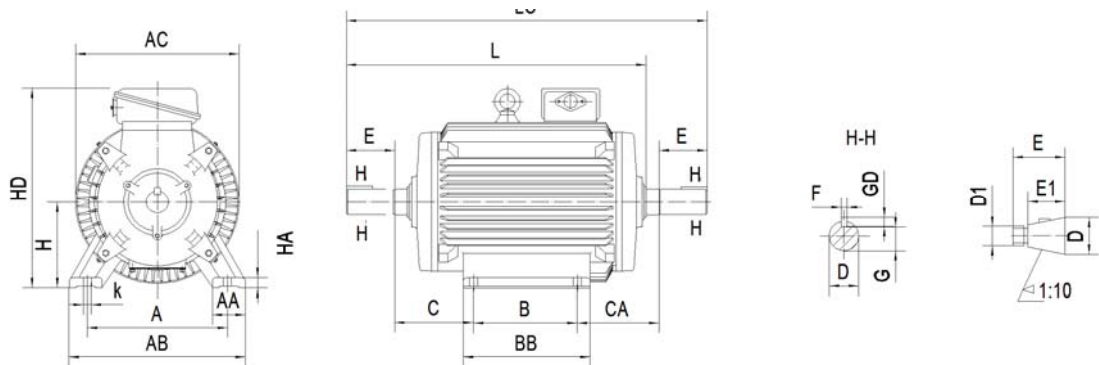

| 机座号 Frame | 安 装 尺 寸 Mounting Dimension | | | | | | | | | | | | | 外 形 尺 寸 Overall Dimension | | | | | | | | |
|--------------|----------------------------|-----|-----|-----|-----|----|------|---------------|-------|-----|-----|------|----|---------------------------|----|-----|-----|-----|----|-----|-----|------|
| | 机 座 Frame | | | | | | | 轴 端 Shaft End | | | | | | AA | AB | AC | BB | HA | HD | L | LC | |
| | A | B | C | CA | H | K | 螺栓直径 | D | D1 | E | E1 | G | GD | | | | | | | | | F |
| 112M | 190 | 140 | 70 | 135 | 112 | 12 | M10 | 32 | — | 80 | — | 27 | 8 | 10 | 50 | 250 | 245 | 235 | 18 | 335 | 420 | 505 |
| 132M | 216 | 178 | 89 | 150 | 132 | 12 | M10 | 38 | — | 80 | — | 33 | 8 | 10 | 50 | 275 | 285 | 260 | 20 | 365 | 495 | 577 |
| 160M | 254 | 210 | 108 | 180 | 160 | 15 | M12 | 48 | — | 110 | — | 42.5 | 9 | 14 | 60 | 320 | 325 | 290 | 25 | 425 | 608 | 718 |
| 160L | 254 | 254 | 108 | 180 | 160 | 15 | M12 | 48 | — | 110 | — | 42.5 | 9 | 14 | 60 | 320 | 325 | 335 | 25 | 425 | 650 | 762 |
| 180L | 279 | 279 | 121 | 180 | 180 | 15 | M12 | 55 | M36×3 | 110 | 82 | 19.9 | 9 | 14 | 70 | 360 | 360 | 380 | 25 | 465 | 685 | 800 |
| 200L | 318 | 305 | 133 | 210 | 200 | 19 | M16 | 60 | M42×3 | 140 | 105 | 21.4 | 10 | 16 | 85 | 405 | 405 | 400 | 28 | 510 | 780 | 928 |
| 225M | 356 | 311 | 149 | 258 | 225 | 19 | M16 | 65 | M42×3 | 140 | 105 | 23.9 | 10 | 16 | 85 | 455 | 430 | 410 | 28 | 545 | 850 | 998 |
| 250M | 406 | 349 | 168 | 295 | 250 | 24 | M20 | 70 | M48×3 | 140 | 105 | 25.4 | 11 | 18 | 95 | 515 | 480 | 510 | 30 | 605 | 935 | 1092 |

IM3001 及 IM3003 卧式安装、机座不带底脚、端盖有凸缘的 YZ 系列电机
 Frame without feet and endshield with flange horizontal mounting motor (IM3001, IM3003)

YZ

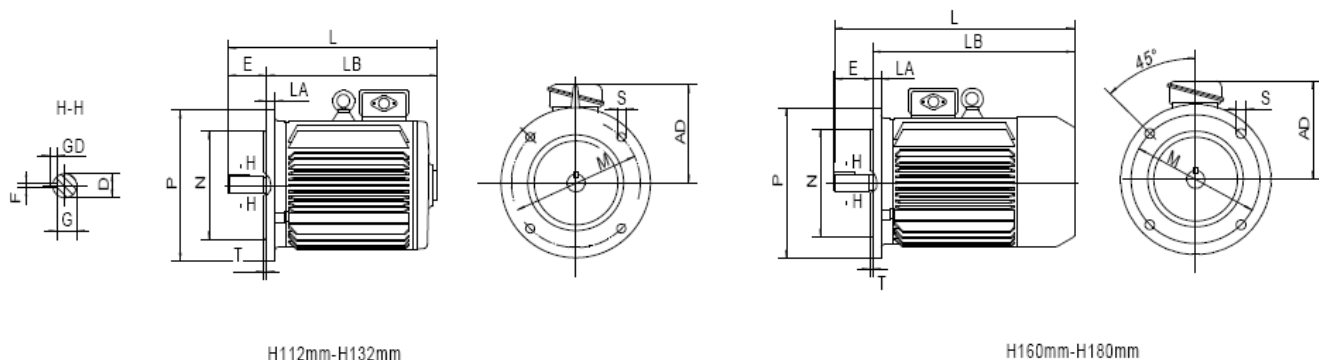

| 机座号 Frame | 安 装 尺 寸 Mounting Dimension | | | | | | | | | | | | | | | | 外形尺寸 Overall Dimension | | |
|--------------|----------------------------|-----|-----|-----|----|---|----|------|-------|---------------|-------|-----|----|----|----|------|---------------------------|-----|-----|
| | 凸 缘 端 Flange | | | | | | | | | 轴 端 Shaft End | | | | | | | Overall Dimension | | |
| | 凸缘号 | M | N | P | LA | T | S | 螺栓直径 | 孔数(个) | D | D1 | E | E1 | F | GD | G | AD | L | LB |
| 112M | FF215 | 215 | 180 | 250 | 14 | 4 | 15 | M12 | 4 | 32 | - | 80 | - | 10 | 8 | 27 | 220 | 430 | 350 |
| 132M | FF265 | 265 | 230 | 300 | 14 | 4 | 15 | M12 | 4 | 38 | - | 80 | - | 10 | 8 | 33 | 230 | 495 | 415 |
| 160M | FF300 | 300 | 250 | 350 | 18 | 5 | 19 | M16 | 4 | 48 | - | 110 | - | 14 | 9 | 42.5 | 260 | 700 | 590 |
| 160L | FF300 | 300 | 250 | 350 | 18 | 5 | 19 | M16 | 4 | 48 | - | 110 | - | 14 | 9 | 42.5 | 260 | 743 | 633 |
| 180L | FF300 | 300 | 250 | 350 | 18 | 5 | 19 | M16 | 4 | 55 | M36×3 | 110 | 82 | 14 | 9 | 19.9 | 280 | 735 | 625 |

IM3011 及 IM3013 立式安装、机座不带底脚、端盖有凸缘、轴伸向下的 YZ 系列电机
Frame without feet, endshield with flange and shaft down mounting motor (IM3011, IM3013)

YZ

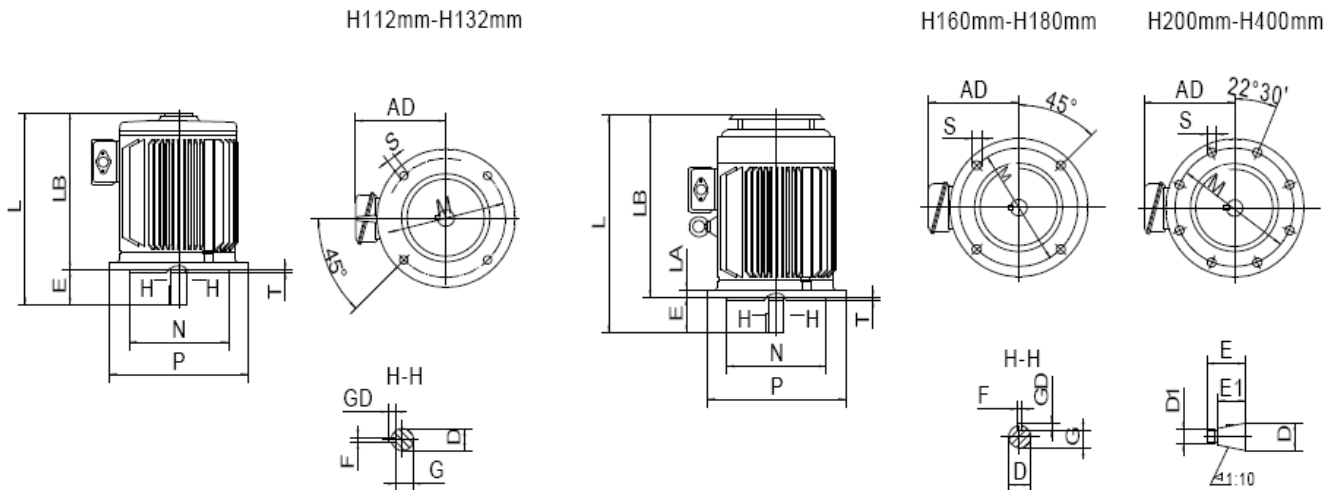

| 机座号 Frame | 安 装 尺 寸 Mounting Dimension | | | | | | | | | | | | | | | | 外形尺寸 Overall Dimension | | |
|--------------|----------------------------|-----|-----|-----|----|---|----|------|-------|---------------|-------|-----|-----|----|----|------|---------------------------|-----|------|
| | 凸 缘 端 Flange | | | | | | | | | 轴 端 Shaft End | | | | | | | Overall Dimension | | |
| | 凸缘号 | M | N | P | LA | T | S | 螺栓直径 | 孔数(个) | D | D1 | E | E1 | F | GD | G | AD | LB | L |
| 112M | FF215 | 215 | 180 | 250 | 14 | 4 | 15 | M12 | 4 | 32 | - | 80 | - | 10 | 8 | 27 | 220 | 350 | 430 |
| 132M | FF265 | 265 | 230 | 300 | 14 | 4 | 15 | M12 | 4 | 38 | - | 80 | - | 10 | 8 | 33 | 230 | 415 | 495 |
| 160M | FF300 | 300 | 250 | 350 | 18 | 5 | 19 | M16 | 4 | 48 | - | 110 | - | 14 | 9 | 42.5 | 260 | 590 | 700 |
| 160L | FF300 | 300 | 250 | 350 | 18 | 5 | 19 | M16 | 4 | 48 | - | 110 | - | 14 | 9 | 42.5 | 260 | 633 | 743 |
| 180L | FF300 | 300 | 250 | 350 | 18 | 5 | 19 | M16 | 4 | 55 | M36×3 | 110 | 82 | 14 | 9 | 19.9 | 280 | 625 | 735 |
| 200L | FF400 | 400 | 350 | 450 | 20 | 5 | 19 | M16 | 8 | 60 | M42×3 | 140 | 105 | 16 | 10 | 21.4 | 320 | 715 | 855 |
| 225M | FF400 | 400 | 350 | 450 | 20 | 5 | 19 | M16 | 8 | 65 | M42×3 | 140 | 105 | 16 | 10 | 23.9 | 320 | 775 | 915 |
| 250M | FF500 | 500 | 450 | 550 | 22 | 5 | 19 | M16 | 8 | 70 | M48×3 | 140 | 105 | 18 | 11 | 25.4 | 355 | 865 | 1005 |

IM1001、IM1003 及 IM1002、IM1004、机座带底脚、端盖无凸缘的 YZR 系列电机
 Frame with feet and endshield without flange (IM1001,IM1002,IM1003,IM1004)

YZR

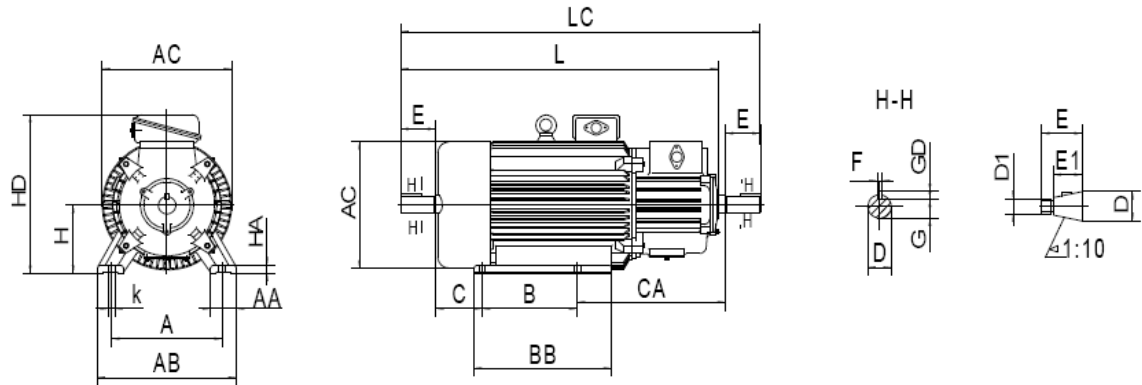

| 机座号 Frame | 安 装 尺 寸 Mounting Dimension | | | | | | | | | | | | | | 外 形 尺 寸 Overall Dimension | | | | | | | |
|--------------|----------------------------|-----|-----|-----|-----|----|----------|---------------|--------|-----|-----|------|----|----|------------------------------|-----|-----|-----|----|-----|------|------|
| | 机 座 Frame | | | | | | | 轴 端 Shaft End | | | | | | | | | | | | | | |
| | A | B | C | CA | H | K | 螺栓 直径 | D | D1 | E | E1 | G | GD | F | AA | AB | AC | BB | HA | HD | L | LC |
| 112M | 190 | 140 | 70 | 300 | 112 | 12 | M10 | 32 | — | 80 | — | 27 | 8 | 10 | 50 | 250 | 245 | 235 | 18 | 335 | 590 | 670 |
| 132M | 216 | 178 | 89 | 300 | 132 | 12 | M10 | 38 | — | 80 | — | 33 | 8 | 10 | 50 | 275 | 285 | 260 | 20 | 365 | 645 | 727 |
| 160M | 254 | 210 | 108 | 330 | 160 | 15 | M12 | 48 | — | 110 | — | 42.5 | 9 | 14 | 60 | 320 | 325 | 290 | 25 | 425 | 758 | 868 |
| 160L | 254 | 254 | 108 | 330 | 160 | 15 | M12 | 48 | — | 110 | — | 42.5 | 9 | 14 | 60 | 320 | 325 | 335 | 25 | 425 | 800 | 912 |
| 180L | 279 | 279 | 121 | 360 | 180 | 15 | M12 | 55 | M36×3 | 110 | 82 | 19.9 | 9 | 14 | 70 | 360 | 360 | 380 | 25 | 465 | 870 | 980 |
| 200L | 318 | 305 | 133 | 400 | 200 | 19 | M16 | 60 | M42×3 | 140 | 105 | 21.4 | 10 | 16 | 85 | 405 | 405 | 400 | 28 | 510 | 975 | 1118 |
| 225M | 356 | 311 | 149 | 450 | 225 | 19 | M16 | 65 | M42×3 | 140 | 105 | 23.9 | 10 | 16 | 85 | 455 | 430 | 410 | 28 | 545 | 1050 | 1190 |
| 250M | 406 | 349 | 168 | 540 | 250 | 24 | M20 | 70 | M48×3 | 140 | 105 | 25.4 | 11 | 18 | 95 | 515 | 480 | 510 | 30 | 605 | 1195 | 1337 |
| 280S | 457 | 368 | 190 | 540 | 280 | 24 | M20 | 85 | M56×4 | 170 | 130 | 31.7 | 12 | 20 | 100 | 575 | 535 | 530 | 32 | 665 | 1265 | 1438 |
| 280M | 457 | 419 | 190 | 540 | 280 | 24 | M20 | 85 | M56×4 | 170 | 130 | 31.7 | 12 | 20 | 100 | 575 | 535 | 580 | 32 | 665 | 1315 | 1489 |
| 315S | 508 | 406 | 216 | 600 | 315 | 28 | M24 | 95 | M64×4 | 170 | 130 | 35.2 | 12 | 22 | 110 | 640 | 620 | 580 | 35 | 750 | 1390 | 1562 |
| 315M | 508 | 457 | 216 | 600 | 315 | 28 | M24 | 95 | M64×4 | 170 | 130 | 35.2 | 12 | 22 | 110 | 640 | 620 | 630 | 35 | 750 | 1440 | 1613 |
| 355M | 610 | 560 | 254 | 630 | 355 | 28 | M24 | 110 | M80×4 | 210 | 165 | 41.9 | 12 | 25 | 120 | 740 | 710 | 730 | 38 | 840 | 1650 | 1864 |
| 355L | 610 | 630 | 254 | 630 | 355 | 28 | M24 | 110 | M80×4 | 210 | 165 | 41.9 | 12 | 25 | 120 | 740 | 710 | 800 | 38 | 840 | 1720 | 1934 |
| 400L | 686 | 710 | 280 | 630 | 400 | 35 | M30 | 130 | M100×4 | 250 | 200 | 50 | 12 | 28 | 136 | 855 | 840 | 910 | 45 | 950 | 1865 | 2120 |



IM3001 及 IM3003 卧式安装、机座不带底脚、端盖有凸缘的 YZR 系列电动机
 Frame without feet and endshield with flange horizontal mounting motor (IM3001, IM3003)

YZR

H112mm-H132mm

H160mm-H180mm

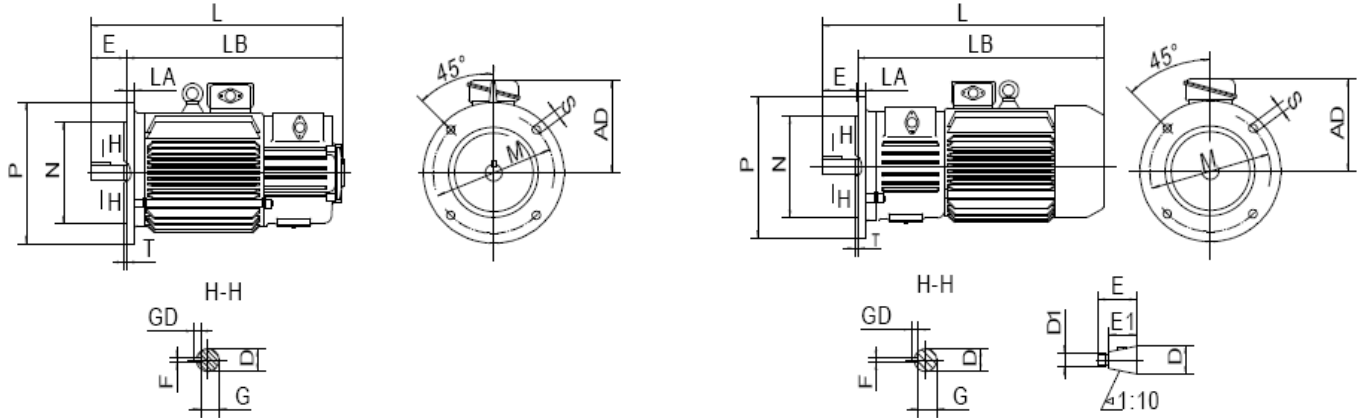

| 机座号 Frame | 安装尺寸 Mounting Dimension | | | | | | | | | | | | | | | | 外形尺寸 Overall Dimension | | |
|--------------|-------------------------|-----|-----|-----|----|---|----|------|-------|--------------|-------|-----|----|----|----|------|---------------------------|-----|-----|
| | 凸缘端 Flange | | | | | | | | | 轴端 Shaft End | | | | | | | | | |
| | 凸缘号 | M | N | P | LA | T | S | 螺栓直径 | 孔数(个) | D | D1 | E | E1 | F | GD | G | | | |
| 112M | FF215 | 215 | 180 | 250 | 14 | 4 | 15 | M12 | 4 | 32 | — | 80 | — | 10 | 8 | 27 | 220 | 515 | 595 |
| 132M | FF265 | 265 | 230 | 300 | 14 | 4 | 15 | M12 | 4 | 38 | — | 80 | — | 10 | 8 | 33 | 230 | 565 | 645 |
| 160M | FF300 | 300 | 250 | 350 | 18 | 5 | 19 | M16 | 4 | 48 | — | 110 | — | 14 | 9 | 42.5 | 260 | 718 | 828 |
| 160L | FF300 | 300 | 250 | 350 | 18 | 5 | 19 | M16 | 4 | 48 | — | 110 | — | 14 | 9 | 42.5 | 260 | 762 | 872 |
| 180L | FF300 | 300 | 250 | 350 | 18 | 5 | 19 | M16 | 4 | 55 | M36×3 | 110 | 82 | 14 | 9 | 19.9 | 280 | 805 | 915 |

IM3011 及 IM3013 立式安装、机座不带底脚、端盖有凸缘、轴伸向下的 YZR 电动机
 Frame without feet, endshield with flange and shaft down mounting motor (IM3011, IM3013)

YZR

H112mm-H132mm

H160mm-H180mm

H200mm-H315mm

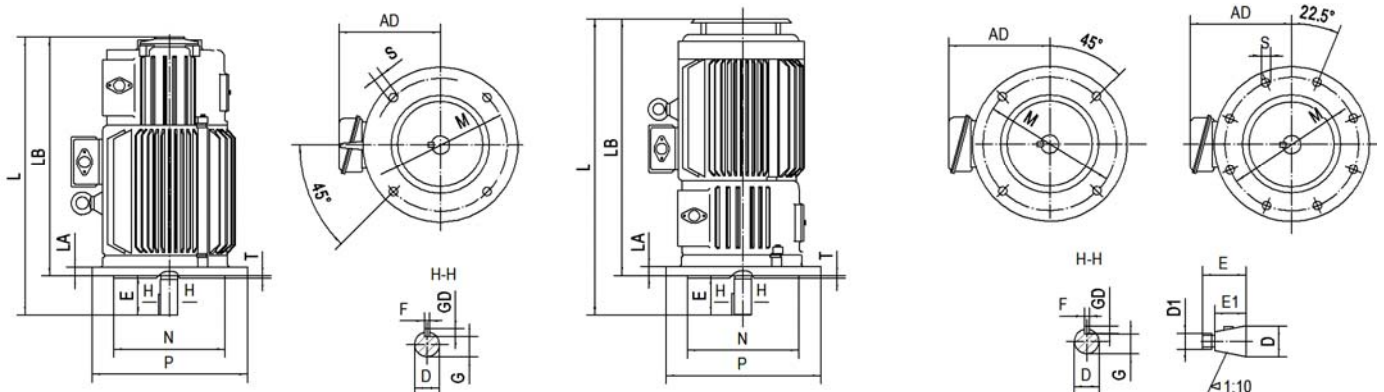

| 机座号 Frame | 安 装 尺 寸 Mounting Dimension | | | | | | | | | | | | | | | | 外形尺寸 Overall Dimension | | |
|--------------|----------------------------|-----|-----|-----|----|---|----|------|-------|---------------|-------|-----|-----|----|----|------|---------------------------|------|------|
| | 凸 缘 端 Flange | | | | | | | | | 轴 端 Shaft End | | | | | | | AD | LB | L |
| | 凸缘号 | M | N | P | LA | T | S | 螺栓直径 | 孔数(个) | D | D1 | E | E1 | F | GD | G | | | |
| 112M | FF215 | 215 | 180 | 250 | 14 | 4 | 15 | M12 | 4 | 32 | — | 80 | — | 10 | 8 | 27 | 220 | 515 | 595 |
| 132M | FF265 | 265 | 230 | 300 | 14 | 4 | 15 | M12 | 4 | 38 | — | 80 | — | 10 | 8 | 33 | 230 | 565 | 645 |
| 160M | FF300 | 300 | 250 | 350 | 18 | 5 | 19 | M16 | 4 | 48 | — | 110 | — | 14 | 9 | 42.5 | 260 | 718 | 828 |
| 160L | FF300 | 300 | 250 | 350 | 18 | 5 | 19 | M16 | 4 | 48 | — | 110 | — | 14 | 9 | 42.5 | 260 | 762 | 872 |
| 180L | FF300 | 300 | 250 | 350 | 18 | 5 | 19 | M16 | 4 | 55 | M36×3 | 110 | 82 | 14 | 9 | 19.9 | 280 | 805 | 915 |
| 200L | FF400 | 400 | 350 | 450 | 20 | 5 | 19 | M16 | 8 | 60 | M42×3 | 140 | 105 | 16 | 10 | 21.4 | 320 | 910 | 1050 |
| 225M | FF400 | 400 | 350 | 450 | 20 | 5 | 19 | M16 | 8 | 65 | M42×3 | 140 | 105 | 16 | 10 | 23.9 | 320 | 970 | 1110 |
| 250M | FF500 | 500 | 450 | 550 | 22 | 5 | 19 | M16 | 8 | 70 | M48×3 | 140 | 105 | 18 | 11 | 25.4 | 355 | 1126 | 1266 |
| 280S | FF500 | 500 | 450 | 550 | 22 | 5 | 19 | M16 | 8 | 85 | M56×4 | 170 | 130 | 20 | 12 | 31.7 | 385 | 1200 | 1370 |
| 280M | FF500 | 500 | 450 | 550 | 22 | 5 | 19 | M16 | 8 | 85 | M56×4 | 170 | 130 | 20 | 12 | 31.7 | 385 | 1250 | 1420 |
| 315S | FF600 | 600 | 550 | 660 | 25 | 6 | 24 | M20 | 8 | 95 | M64×4 | 170 | 130 | 22 | 12 | 35.2 | 435 | 1305 | 1475 |
| 315M | FF600 | 600 | 550 | 660 | 25 | 6 | 24 | M20 | 8 | 95 | M64×4 | 170 | 130 | 22 | 12 | 35.2 | 435 | 1355 | 1525 |

常用的结构及安装型式，以及适用的机座号见下表

Conventional mounting type and suitable frame size are given in following table

| 安装型式 Mounting Type | 代号 Symbol | 制造范围（机座号） Range (Frame Size) | | 备注 Note |
|---|--------------|---------------------------------|---------|------------------------------------|
| | | YZ 系列 | YZ 系列 | |
|  | IM1001 | 112~160 | 112~160 | 单圆柱轴伸 Single Cylindrical Shaft End |
| | IM1003 | 180~250 | 180~400 | 单锥形轴伸 Single Conical Shaft End |
|  | IM1002 | 112~160 | 112~160 | 双圆柱轴伸 Double Cylindrical Shaft End |
| | IM1004 | 180~250 | 180~400 | 双锥形轴伸 Double Conical Shaft End |
|  | IM3001 | 112~160 | 112~160 | 单圆柱轴伸 Single Cylindrical Shaft End |
| | IM3003 | 180 | 180 | 单锥形轴伸 Single Conical Shaft End |
|  | IM3011 | 112~160 | 112~160 | 单圆柱轴伸 Single Cylindrical Shaft End |
| | IM3013 | 180~250 | 180~315 | 单锥形轴伸 Single Conical Shaft End |